

NAME (please print) _____ SID _____

UNIVERSITY OF CALIFORNIA, BERKELEY
Electrical Engineering and Computer Sciences Department

EECS 145L Electronic Transducer Lab
MIDTERM #1 (100 points maximum)
October 6, 2004

(closed book, calculators OK, equation sheet provided)
(You will not receive full credit if you do not show your work)

PROBLEM 1 (16 points)

1a (8 points) Give two important differences between Johnson noise and shot noise.

1b (8 points) Give two important differences between Johnson noise and electromagnetic interference noise.

PROBLEM 2 (20 points)

2a (10 points) Derive an equation for the output V_0 of the differential amplifier shown below as a function of the input voltages V_3 and V_4 and the resistors R_3 and R_4 . Assume that the negative feedback keeps both op-amp inputs at the same voltage.

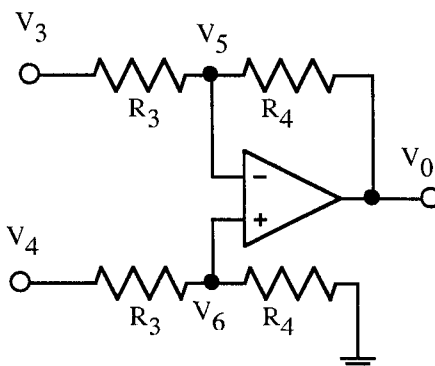

2b (5 points) Using the equation derived in part 2a, write an equation for the differential and common-mode gains as functions of the resistors R_3 and R_4 .

PROBLEM 3 (20 points)

You have been asked to analyze the standard instrumentation amplifier, shown below:

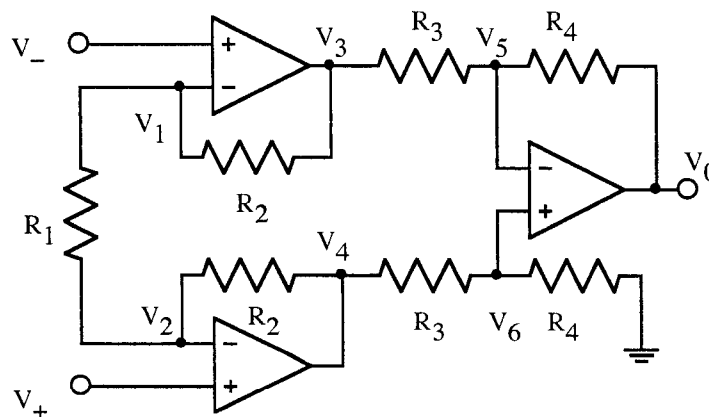

- 3a** (8 points) Derive an equation for the common mode gain $(V_4+V_3)/(V_++V_-)$ of the *first* stage of the above instrumentation amplifier. Assume that the negative feedback keeps both op-amp inputs at the same voltage.
- 3b** (8 points) Derive an equation for the differential gain $(V_4-V_3)/(V_+-V_-)$ of the *first* stage of the instrumentation amplifier shown above. Assume that the negative feedback keeps both op-amp inputs at the same voltage.
- 3c** (4 points) Derive an equation for the differential gain $V_o/(V_+-V_-)$ of the *entire* instrumentation amplifier shown above. (Hint: combine the results from 3b and 2a above)

PROBLEM 4 (20 points)

You have been asked to analyze the a new instrumentation amplifier design, shown below:

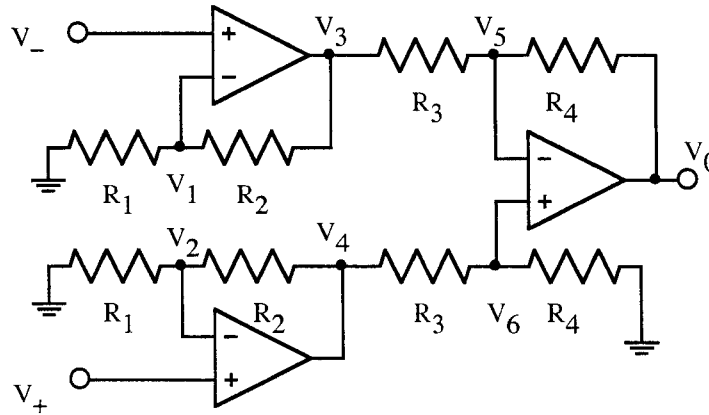

- 4a** (8 points) Derive an equation for the common mode gain $(V_4+V_3)/(V_++V_-)$ of the first stage of the new instrumentation amplifier design shown above. Assume that the negative feedback keeps both op-amp inputs at the same voltage.
- 4b** (8 points) Derive an equation for the differential mode gain $(V_4-V_3)/(V_+-V_-)$ of the first stage of the new instrumentation amplifier design shown above. Assume that the negative feedback keeps both op-amp inputs at the same voltage.

- 4c (4 points) Is the new instrumentation amplifier design better than the standard design (problem 3 above)? If not, why not?

PROBLEM 5 (16 points)

You are asked to design a system for measuring the height of a liquid in a tank 10 m high. As the water level changes, the float rises and falls, and the cable winds on the pulley and raises and lowers the contact point on the resistor. Assume that the contact is at the bottom end of the resistor when the tank is full and at the top end of the resistor when the tank is empty.

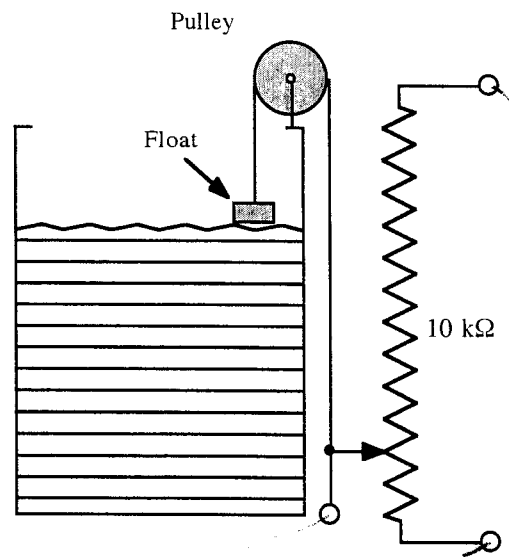

- 5a (8 points) Design a circuit that produces a 10 V output when the tank is full and 0V when the tank is empty. The output must drive the recording circuit which is a 10 kΩ load.

5b (8 points) You perform repeated measurements of the output of your circuit when the height of the liquid is constant and find that the output voltage has a standard deviation of 1 mV. If a measurement is taken every minute, how accurately could you determine the change in the liquid level per minute?

PROBLEM 6 (8 points)

Design a filter circuit with the following gain characteristics. Do not show resistors and capacitors, just a box for each filter, showing input, output, type of filter, order number n , and corner frequency

Frequency (Hz)	Gain
0.1	0.10
1.0	0.71
10	1.00
100	1.00
1,000	1.00
10,000	0.71
100,000	0.01
1,000,000	0.0001

NAME: _____ TA: _____ SECTION #: _____

**CS 61A
Fall 2002**

Midterm #3

L. Rowe

This examination is open book and notes, but closed friends! Answer all questions in the space provided. Some questions have procedures with blank lines where you are to give an answer. You are to provide one expression for each blank line. If you do not understand a question, please ask the proctor for clarification.

Circle Login

Question	Score	Total Possible
1.		(10 possible)
2.		(10 possible)
3.		(30 possible)
4.		(20 possible)
5.		(20 possible)
6.		(10 possible)
<hr/>		
TOTAL		(100 possible)

Oath

I certify that I am the student whose name appears above.

Signature: _____

Student ID #: _____

Seating Row: _____ Room: _____

On my left: Name: _____ Login: _____

On my right: Name: _____ Login: _____