

EE 40: Introduction to Microelectronic Circuits

Spring 2008: Midterm 2

Venkat Anantharam

03/19/08

Total Time Allotted : 50 min

Total Points: 50

1. This is a closed book exam. However, you are allowed to bring two pages (8.5 x 11) notes, with writing on both sides.
2. No electronic devices, i.e. calculators, cell phones, computers, etc.
3. Show the steps used to arrive at your answer, where necessary. Partial credit will be given if you have the proper steps but an incorrect answer. A correct answer for a problem involving multiple steps where it is not clear how you arrived at the answer may not be given full credit.
4. Write your final answers into the boxes.
5. Remember to put down units.

Last (Family) Name:			
First Name:			
Student ID:		Lab Section:	
Signature:			

		Max	Score
1	(a-g)	10	
1	(h-k)	10	
2		6	
3	(a)	4	
3	(b)	4	
4		10	
5		6	
Total		50	

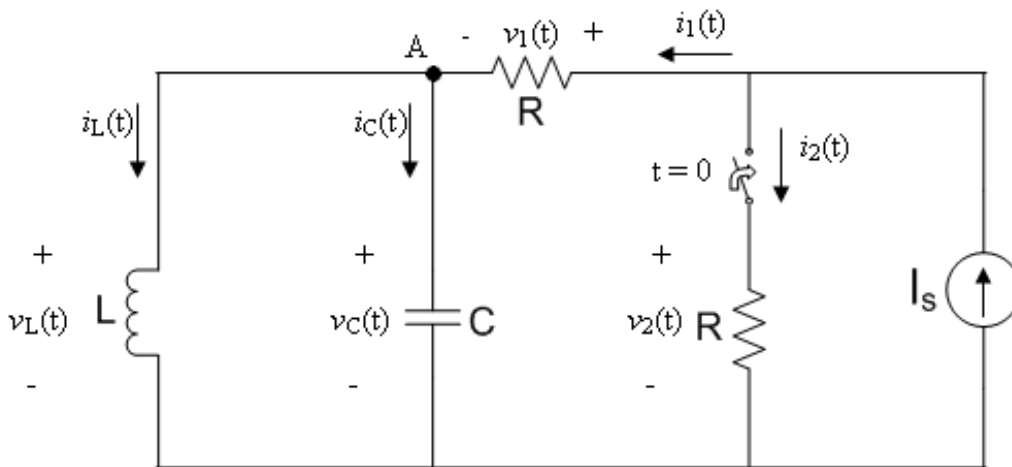

In the circuit shown above the current source is a DC source. The switch is open prior to time 0, and the current has reached steady state prior to time 0.

At time 0 the switch closes.

The reference configuration to use for each circuit element in solving the problem is shown in the figure. Please provide all answers in terms of I_s , R , L , and C .

(a) What is $i_L(0_-)$? (2 pts)

$$i_L(0_-) =$$

(b) What is $v_C(0_-)$? (2 pts)

$$v_C(0_-) =$$

(c) What is $i_L(0_+)$? (1 pt)

$$i_L(0_+) =$$

(d) What is $v_C(0_+)$? (1 pt)

$$v_C(0_+) =$$

(e) What is $i_1(0_+)$? (2 pts)

$$i_1(0_+) =$$

(f) What is $i_C(0_+)$? (1 pt)

$$i_C(0_+) =$$

(g) What is $\frac{dv_C}{dt}(0_+)$? (1 pt)

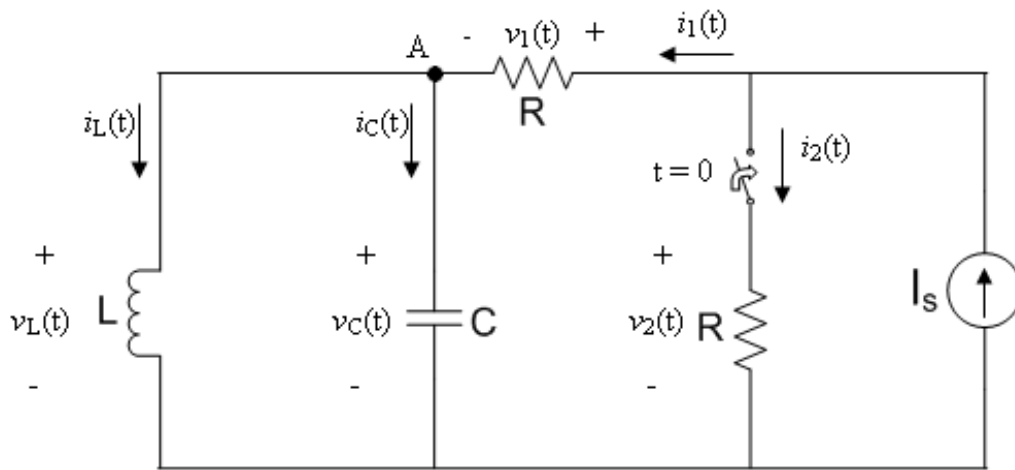

For your convenience the circuit after the switch closes at time $t = 0$ is redrawn below. Use the same reference configurations as in the original figure.

The rest of the problem refers to the situation after time 0.

- (h) Writing an appropriate KVL equation, express $i_1(t)$ in terms of $v_C(t)$ (and the parameters I_s , R , L , and C if needed) for $t \geq 0_+$. (2 pts)

$$i_1(t) =$$

- (i) Using KCL at node A , express $i_L(t)$ in terms of $v_C(t)$ and the parameters for $t \geq 0_+$. (2 pts)

$$i_L(t) =$$

(j) Write down a differential equation that $v_C(t)$ must satisfy for $t \geq 0$. (4 pts)

(k) For what combination of parameter values is the circuit critically damped for $t \geq 0_+$?
(Note: if your answer depends on I_s , you have done something wrong). (2 pts)

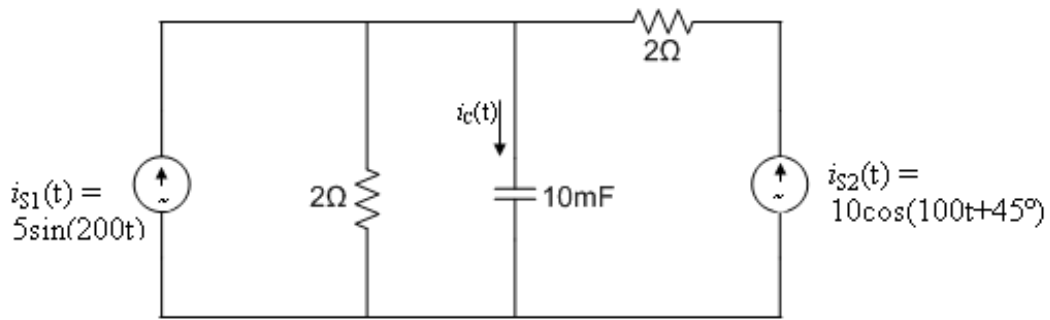

2. (6 pts) In the circuit above the two sources are at different frequencies $\omega_1 = 200\text{rad/sec}$ and $\omega_2 = 100\text{rad/sec}$ respectively.

Use superposition and phasor analysis to determine $i_C(t)$.

$$\arctan 2 = 63.435^\circ$$

$$\arctan 4 = 75.96^\circ$$

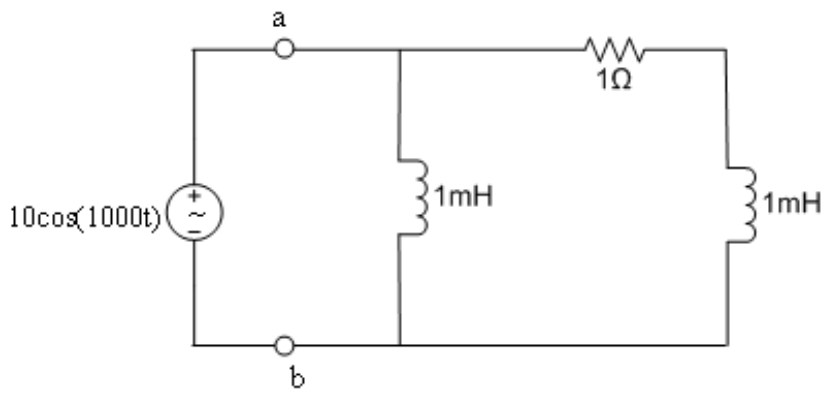

3. (8 pts total) Consider the circuit above operating in AC steady state at frequency $\omega = 1000\text{rads/sec}$.
(a) What is the average power dissipated in the resistance? (4 pts)
-

$P_{avg} =$

(b) We now want to put a capacitor in parallel with the load across the terminals a and b, resulting in the circuit below.

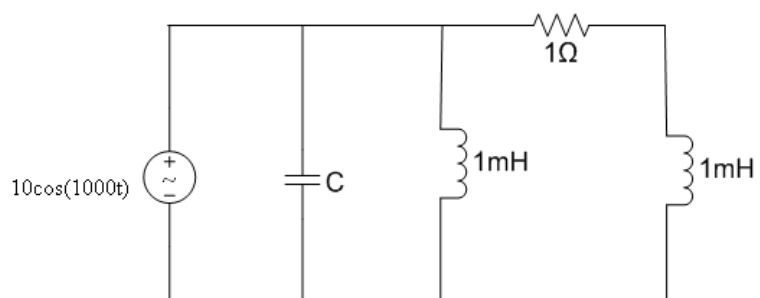

What should be the value of C such that no reactive power is drawn from the source? (4 pts)

$C =$

4. (10 pts total)

Bode plots:

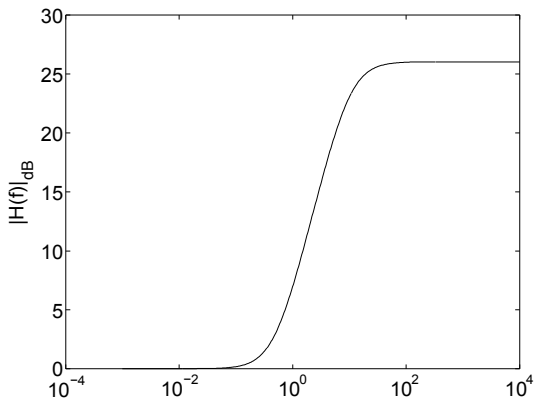

(a) Plot A

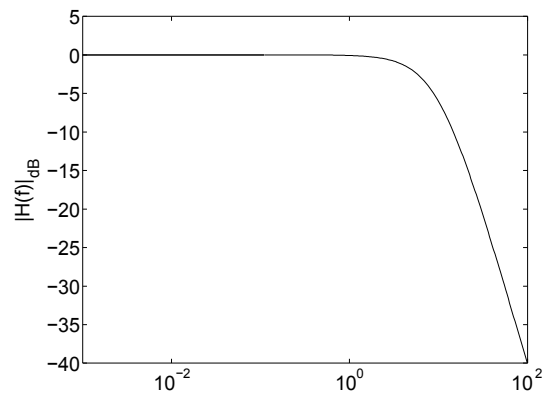

(b) Plot B

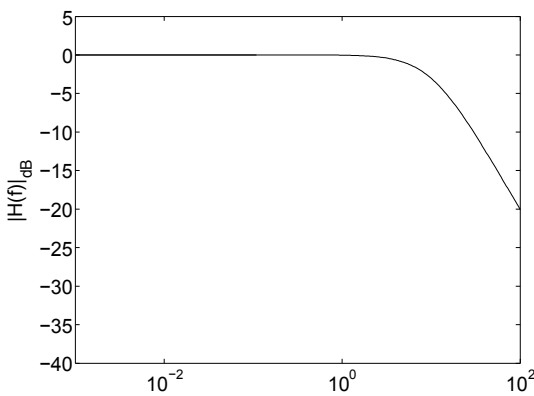

(c) Plot C

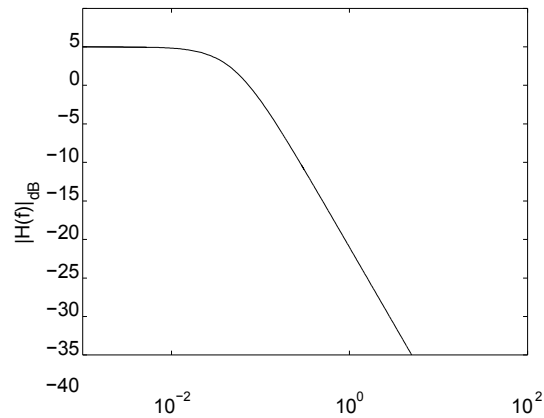

(d) Plot D

Match the magnitude Bode plots (above) with the corresponding transfer functions (below) (4 pts).

Transfer function	$H_1(\omega) = \frac{1}{1+j20\omega}$	$H_2(\omega) = \frac{10+j20\omega}{10-j\omega}$	$H_3(\omega) = \frac{10}{10+j\omega}$	$H_4(\omega) = \frac{10}{(10+j\omega)^2}$
Corresponding Bode plot (a,b,c, or d?):				

Explain your reasoning (6 pts):

5. (6 pts)

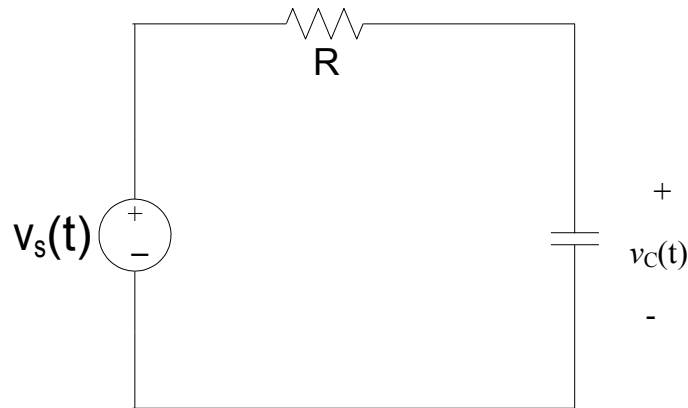

Figure 1:
Circuit

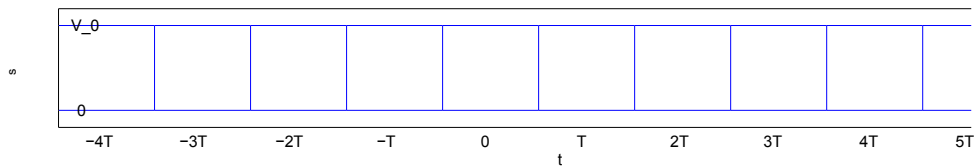

Figure 2: Voltage
source

In the circuit above (Fig. 1) the voltage source is periodic with period $2T$ and alternates between a value of V_0 for T seconds, followed by a value of 0 for T seconds as shown (Fig. 2).

Sketch the steady state response $v_C(t)$, labeling the graph completely, i.e. $v_C(t)$ should be determined exactly. You need not explain the details by which you arrived at $v_C(t)$. However, you should explain why your sketched $v_C(t)$ is correct.

(Hint: Try to think about the values that the steady state $v_C(t)$ should have when t lies in an interval that is an even multiple of T and the value it should have when t lies in an interval that is an oddmultiple of T . Write two equations, relating these two values, using your understanding of RC circuits.)